

Standard KRA Series

常见真空度 55kPa以下
流量 1130~1850L/min (50Hz)

Continuous operative vacuum 55kPa or low
Capacity 1130~1850L/min (50Hz)

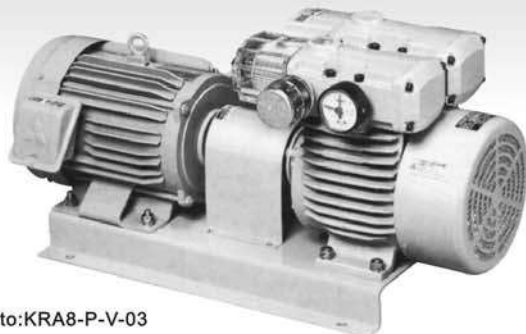

Photo:KRA8-P-V-03

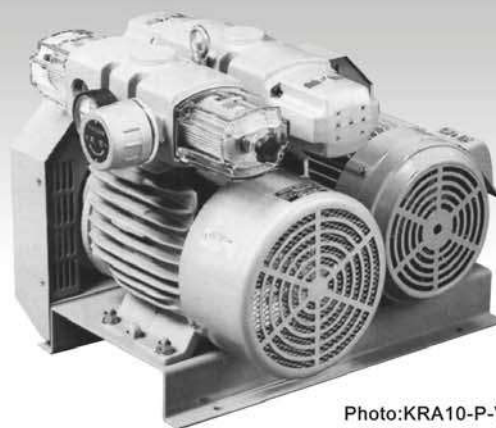

Photo:KRA10-P-V-03

特长

- 因为是无油式，所以在使用真空（真空规格）、排气（鼓风规格）时，也不含有油分，不会对作业环境和产品（物体）造成油污染。
- 运行声音低、寿命长。而且同时装备有真空压力表、调压控制阀。
- 大流量型最适合于印刷机械、装订机械等的大型化、高速化以及集中配管系统。

Features

- No oil in either vacuum, pressure or combination application.
- Quiet operation.
- Long Life.
- Gauge and controller equipment standard.
- Dependable proven Design for continuous duty operation.
- Designed for printing press applications.

性能

Specifications

型式 Model	设计排气量 Designed pumping capacity		到达真空度 Ultimate vacuum (kPa以上) (※2)	常用真空度 Continous operative vacuum (kPa以下) (※3)	常用排气压力 Continuous operative pressure (kPa以下) (※3)	配管 接口 Suction. Exhaust port diameter	电源 Motor voltage					运转噪音 (dB) Noise		装载电机 (kw) Motor	质量(kg) Mass	
	(L/min)(※1)		(Over:kPa)				三相 Three phase									三相 Three phase
	50Hz	60Hz					200V	380V	400V	415V	440V	50/60Hz	50Hz	60Hz		

KRA8-P-□-□

V-03	1130	1350	90	55	-	Rc1	○	○	○	○	○	67	68	2.2	98
B-03	1130	1350	-	-	50	Rc1	○	○	○	○	○	74	76	2.2	98
VB-03	1130	1350	90	合计55kPa以下		Rc1	○	○	○	○	○	67	68	2.2	98

KRA10-P-□-□

V-03	1850	2200	90	55	-	Rc11/4	○	○	○	○	○	74	75	3.7	127
B-03	1850	2200	-	-	50	Rc11/4	○	○	○	○	○	76	77	3.7	127
VB-03	1850	2200	90	合计55kPa以下		Rc11/4	○	○	○	○	○	74	75	3.7	127

※1设计排气量：由容积所计算出的理论值。实际流量参考性能实测数据。

※2泵所到达最高真空点在实际上不能使用。只是为了机种选定时计算而使用。

※3可能使用的真空度（排气压力）范围。

※使用环境（吸入空气）条件：温度：0~40℃、湿度：通常湿度（65±20%）

※电源电压的允许波动范围为额定电压±10%。

※请设置过负荷保护器（热敏继电器等）。

设定值：请以电机标牌上记载的额定电流值为标准。

※ 1 Design displacement: Logic value calculated from the cubic volume. Regarding the actual flow rate, refer to the actual measurement data of performance.

※ 2 It is not allowable to use it at the maximum vacuum reaching point of the pump. Use it for model selection calculations.

※ 3. Usable range of the degree of vacuum (exhaust pressure) range.

※ In the KRA8, KRA10, various independent pumps are also available.

※ As the intake gas, use clean air of ordinary temperature and ordinary humidity whenever possible. [Using environmental conditions (intake air) should be 0~40℃ in the temperature and 65±20% in the humidity].

※ The allowable variation range of the supply voltage should be rated voltage(10%).

※ Install an overload protector (thermal relays, etc.). setting value: Use the rated current value being indicated on the specification plate of the motor as target value.

性能实测数据 (- 50Hz)

Performance data

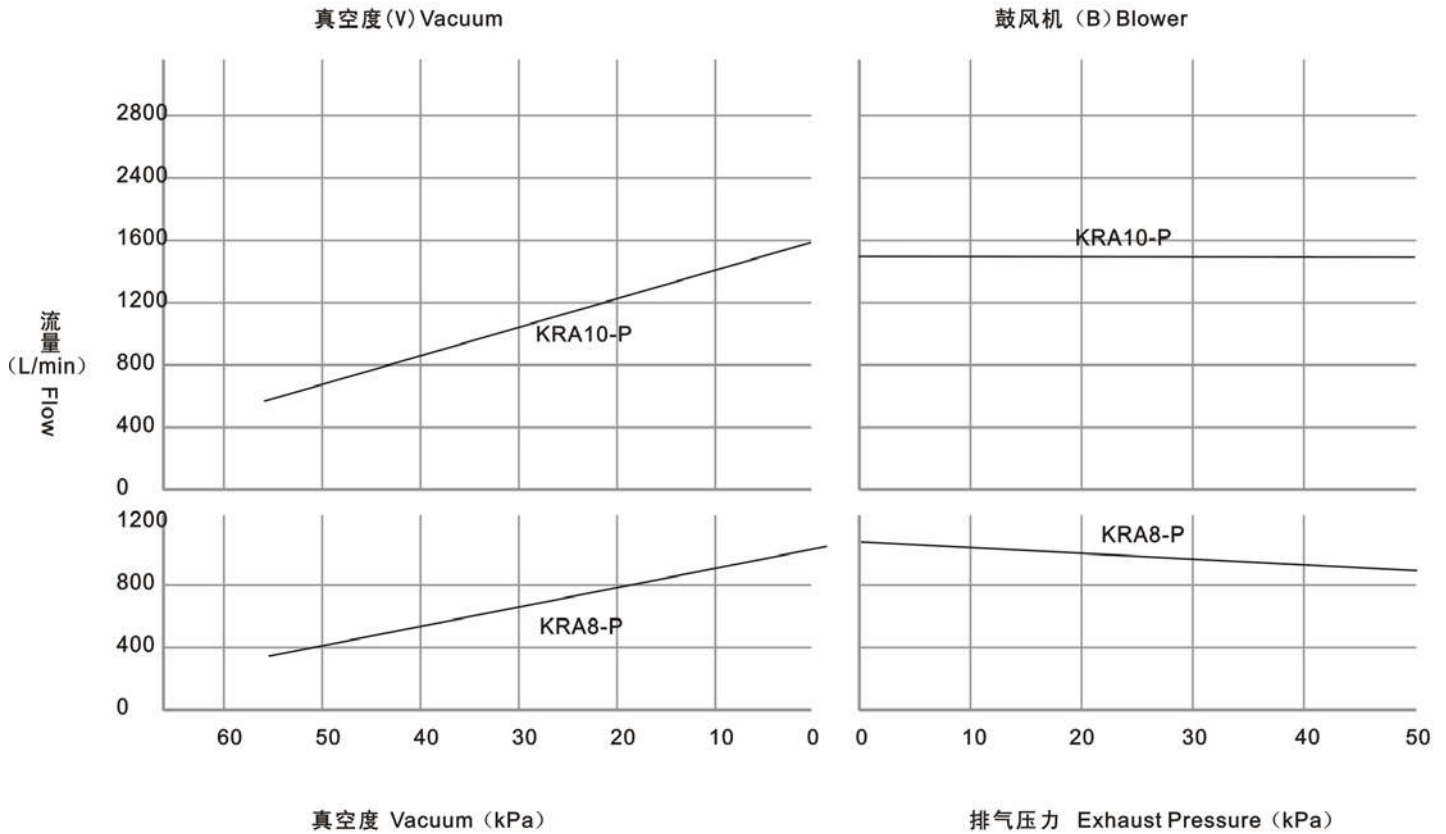

※ 1大气压下20°C

※ Under one normal atmospheric pressure 20°C

外形尺寸 (尺寸单位: mm)

Outer dimensions (Unit:mm)

KRA8-P-□-03

※ 图示是真空规格尺寸

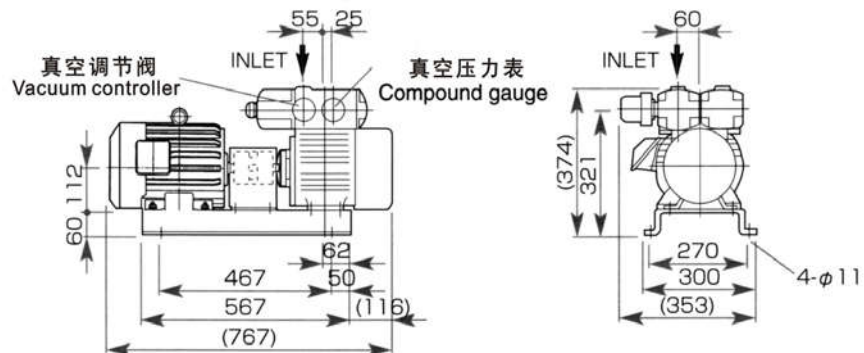

KRA10-P-□-03

※ 图示是真空规格尺寸

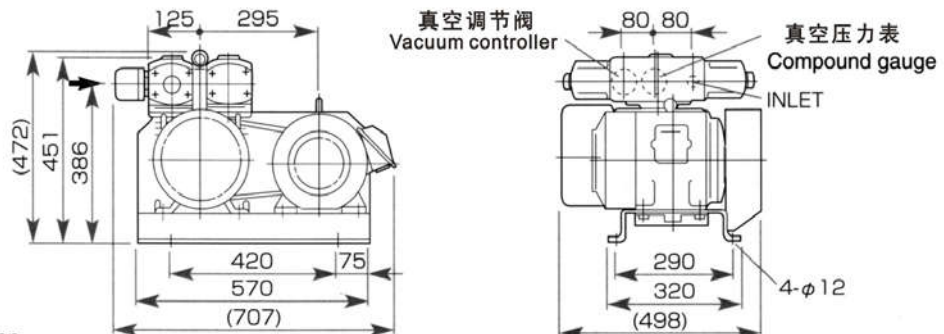

※ 图表表示真空规格

※ Drawings are for vacuum application.